

ALL-PLASTIC VARIABLE AREA FLOWMETERS

Introduction

Variable Area Flowmeters are often the best option when the application is simple and you need an economical solution. Over the last 30 years many thousands of DFM units have been supplied to practically every industry in the UK. All units are available for quick delivery from our extensive stock and can be scaled for gases or liquids in any engineering units.



Technical Data

Accuracy	±2.5% full scale
Max Pressure	10 Bar operating (at 20°C - see chart for operating pressures versus temperature)
Temperature	PVC 60°C, PA 75°C, PSU 100°C (see chart for operating pressures versus temperature)
Scaling	L/hr H2O standard plus 0-100% max flow. Custom Liquid/Gas scales available
Flow Ranges	See page 4

Installation & Use

Pipework

PVC female BSP, metric and imperial sockets, ABS sockets, polypropylene sockets, cast steel & stainless steel BSP inserts.

Installation

Vertical - flow upwards. For best results ensure pipework vertical to within 2/3°.

Valves

For liquids may be installed upstream or downstream. For gases install valves downstream only.

ALL-PLASTIC VARIABLE AREA FLOWMETERS

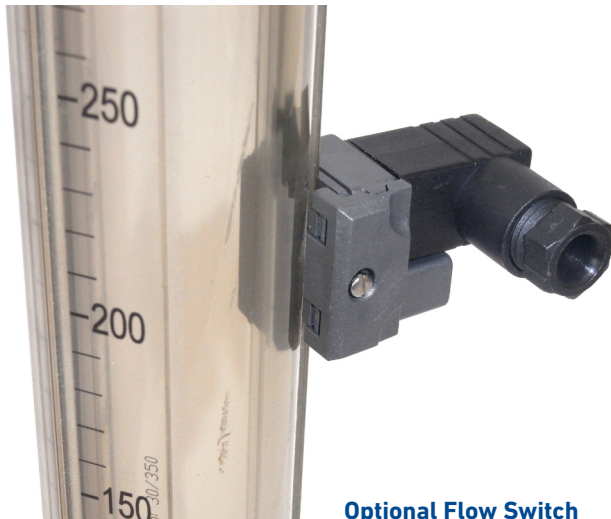

Optional Flow Switch

Advantages

- 3-50,000 litres/hour liquid in 28 ranges each with 10:1 operating span
- 5 different overall lengths from 165-350mm
- Choice of tube materials depending upon operating temperature and pressure up to 100°C and 10 Bar
- Positive pipe O-ring sealing requiring less tightening effort when installing
- Standard or magnetic floats (where alarms required) of identical mass ensure identical flow ranges when changing
- Optional bi-stable adjustable alarm on rear slide
- Optional 4-20 mA transmitter
- Special Scales produced for liquids and gasses other than water or air

Optional Equipment

Up to 3 in number bi-stable or mono-stable switches, comprising volt free contacts to handle 240V 5 amp max current. A 4-20mA transmitter is also available.

Materials

Tube Material	Polyamide, PVC, Polysulphon
End Fittings	Rigid PVC socket connections for adhesive pipe coupling. BSP threads available. Special stainless steel inserts available. Cast iron end caps for higher temperature
Float	Fully encapsulated PVDF. Stabilising ring fitted to larger sizes ensuring steady flow indication without wobble
Float Tops	PVDF
O Rings	Standard EPDM, Special Viton, etc. available



Optional 4-20mA Transmitter

ALL-PLASTIC VARIABLE AREA FLOWMETERS

Dimensions & Parts

Series DFM 165-170-185-200-350

Part	No.	Description
1	1	Measuring Tube
2	1	Float
3	2	Float Trap
4	2	Union Nut
5	2	Insert
6	2	O-Rings
7	2	Set-Point Indicator

Materials of Construction

	Standard	Options
Tube	Polyamide	PVC, Polysulphon
Float	PVDF	
Float Trap	PVDF	
Union Nut	PVC	Cast Iron, ABS PP
Insert	PVC	Stainless Steel
O-Rings	EPDM	Viton Teflon

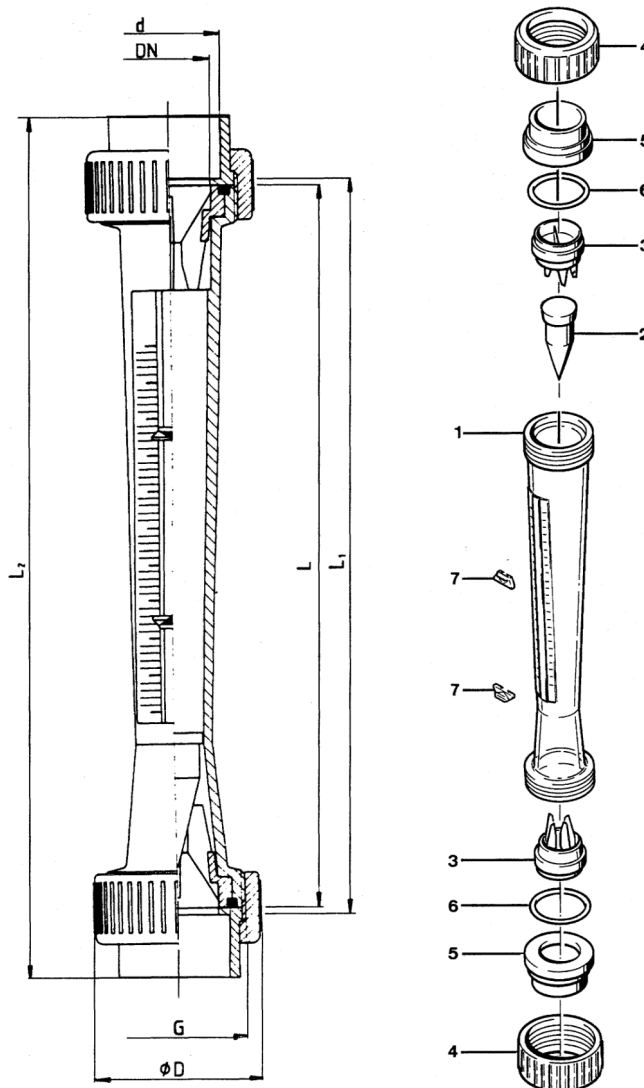

Series DFM	Dimensional mm		BSPF DN Inches	G	D	L	L1	L2	P(1) m bar	Weight in grams (2)
	DN	d								
165	10	16	3/8"	3/4"	35	165	171	199	4.6	78
170	15	20	1/2"	1"	43	170	176	208	4.5	96
185	20	25	3/4"	1 1/4"	53	185	191	229	6.1	125
200	25	32	1"	1 1/2"	60	200	206	250	8.3	250
350	25	32	1"	1 1/2"	60	350	356	400	16.2	475
350	32	40	1 1/4"	2"	72	350	356	408	16.2	710
350	40	50	1 1/2"	2 1/4"	83	350	356	418	16.2	1.050
350	50	63	2"	2 3/4"	103	350	356	432	27.6	1.530
350	65	75	2 1/2"	3 1/2"	122	350	356	444	40.7	2.100

ALL-PLASTIC VARIABLE AREA FLOWMETERS

Sizing Table

Nominal Size DN ins BSP	Socket Bore 'd' mm	Air Range NM3/hr 1 Bar/Abs 20°C	Water Range l/hr 20°C	PVC Tube		Polyamide Tube		Polysulphon Tube	
				Std Float	Mag Float	Std Float	Mag Float	Std Float	Mag Float

Series DFM 165

Range

Model Number

3/8"	17.1	0.2-1.0	3-22	47500	47683	47516	47699	47532	47715
3/8"	17.1	0.3-2.2	5-60	47501	47684	47517	47700	47533	47716
3/8"	17.1	0.5-3.5	10-100	47502	47685	47518	47701	47534	47717
3/8"	17.1	1-8.5	25-250	47503	47686	47519	47702	47535	47718

Series DFM 170

1/2"	21.4	0.4-2.4	5-50	47504	47687	47520	47703	47536	47719
1/2"	21.4	0.8-6.4	15-150	47505	47688	47521	47704	47537	47720
1/2"	21.4	1.2-10	25-250	47506	47689	47522	47705	47538	47721
1/2"	21.4	2-15.5	40-400	47507	47690	47523	47706	47539	47722

Series DFM 185

3/4"	26.5	0.8-5.6	15-150	47508	47691	47524	47707	47540	47723
3/4"	26.5	2-14	40-400	47509	47692	47525	47708	47541	47724
3/4"	26.5	2.4-20	60-600	47510	47693	47526	47709	47542	47725
3/4"	26.5	4-36	100-1000	47511	47694	47527	47710	47543	47726

Series DFM 200

1"	33.6	1.2-9	25-250	47512	47695	47528	47711	47544	47727
1"	33.6	2-14	40-400	47513	47696	47529	47712	47545	47728
1"	33.6	4-35	100-1000	47514	47697	47530	47713	47546	47729
1"	33.6	6-50	150-1500	47515	47698	47531	47714	47547	47730

Series DFM 350

1"	33.6	2.5-20	60-600	46276	47580	46303	47607	46330	47634
1"	33.6	4-32	100-1000	46277	47581	46304	47608	46331	47635
1 1/4"	42.2	5-50	150-1500	46279	47583	46306	47610	46333	47637
1 1/4"	42.2	10-80	250-2500	46280	47584	46307	47611	46334	47638
1 1/2"	48.3	7-65	200-2000	46284	47588	46311	47615	46338	47642
1 1/2"	48.3	10-90	300-3000	46285	47589	46312	47616	46339	47643
2"	60.3	14-125	400-4000	46289	47593	46316	47620	46343	47647
2"	60.3	22-190	600-6000	46290	47594	46317	47621	46344	47648
2"	60.3	35-300	1000-10000	46291	47595	46318	47622	46345	47649
2 1/2"	75.2	50-500	1500-15000	46295	47599	46322	47626	46349	47653
2 1/2"	75.2	80-720	2500-25000	46296	47600	46323	47627	46350	47654
2 1/2"	75.2	400-1500	10000-50000	46297	47601	46324	47628	46351	47655

Note: For air or gas flows model number may vary and will be advised at order stage

 Ex Stock Flowmeters

ALL-PLASTIC VARIABLE AREA FLOWMETERS

Temperature vs. Pressure Rating

Care should be taken to observe the maximum operating temperature for various tube materials, the curve illustrates the maximum operating pressure for temperatures above 20°C.

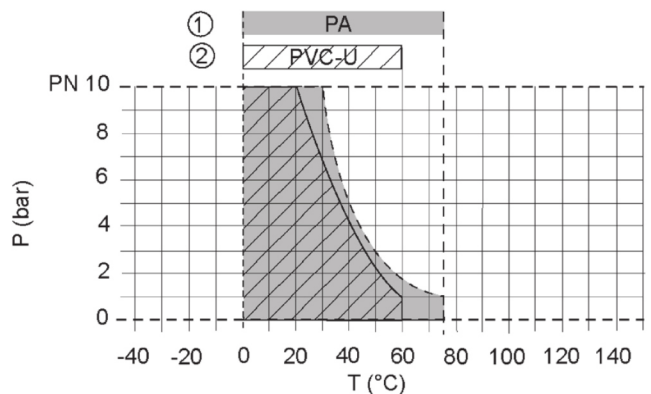
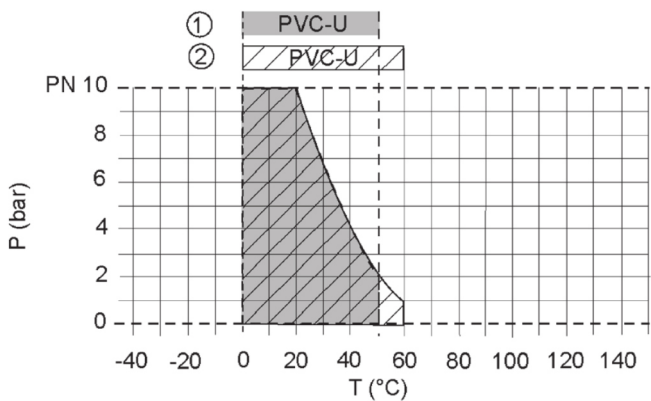
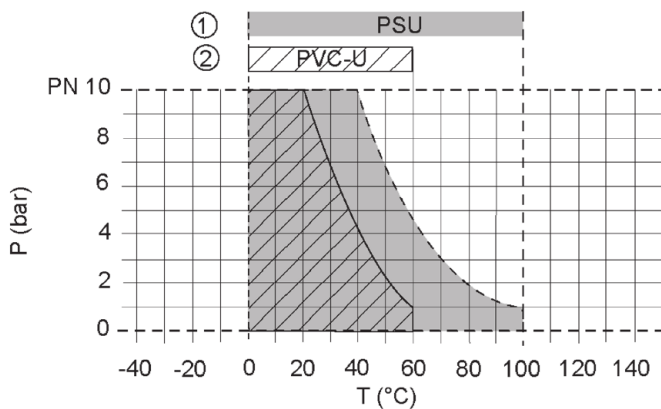

Special Scales

Computer calculated and plotted scales are available which incorporate all these variables and also for gas flow measurement at varying temperatures, pressures, densities and viscosities.

Operating Principle

The DFM Variable Area Flowmeters use a float in a tapered tube constructed of plastic.

The liquid/gas flows vertically through the tube forcing the float to rise while allowing the liquid/gas to pass around the float.

The pressure drop (defined by the size of the float) across the flowmeters range remains constant - see chart on page 3.

The measurement reading is taken from the top (or widest part) of the float against the scale on the tube.

Float Types

